

Model Number	Nominal Size (Inches) W x H x D	Actual Size (Inches) W x H x D	Rated Air Flow (CFM)	Initial Resistance (In. W.G.)	Media Area (Square Feet)
DP40-STD4-410	12 X 24 X 4	11-3/8 X 23-3/8 X 3-3/4	1000	0.17	12.4
DP40-STD4-401	16 X 20 X 4	15-1/2 X 19-1/2 X 3-3/4	1120	0.17	14.5
DP40-STD4-402	16 X 25 X 4	15-1/2 X 24-1/4 X 3-3/4	1400	0.17	18.3
DP40-STD4-412	18 X 24 X 4	17-3/8 X 23-3/8 X 3-3/4	1500	0.17	19.9
DP40-STD4-403	20 X 20 X 4	19-1/2 X 19-1/2 X 3-3/4	1400	0.17	18.7
DP40-STD4-411	20 X 24 X 4	19-3/8 X 23-3/8 X 3-3/4	1670	0.17	22.4
DP40-STD4-404	20 X 25 X 4	19-1/2 X 24-1/2 X 3-3/4	1750	0.17	23.5
DP40-STD4-405	24 X 24 X 4	23-3/8 X 23-3/8 X 3-3/4	2000	0.17	27.4
DP40-STD4-428	25 X 29 X 4*	24-1/2 X 28-1/2 X 3-3/4	2430	0.17	32.6
DP40-STD4-431	28 X 30 X 4*	27-1/2 X 29-1/2 X 3-3/4	2920	0.17	38.5

*Reverse Pleat Direction

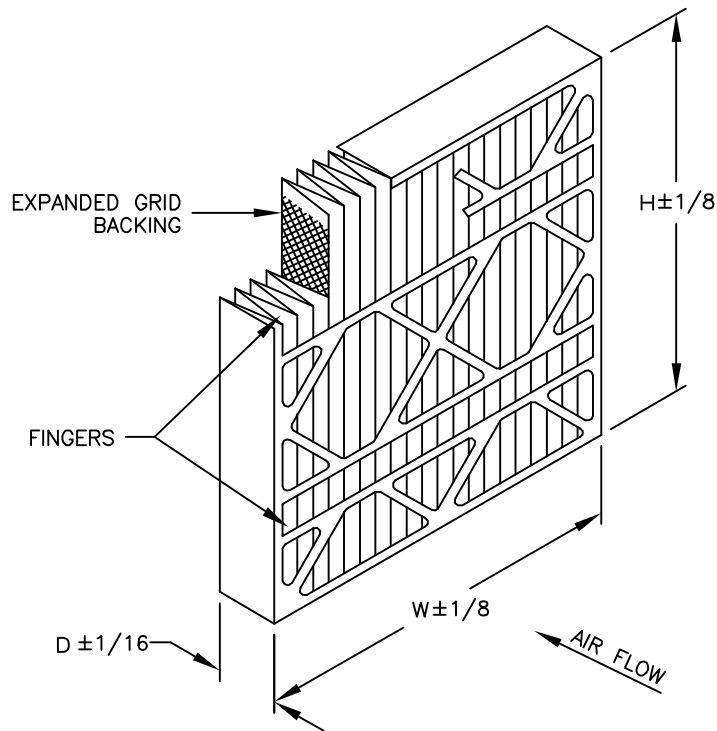

STANDARD CONSTRUCTION

- 100% Synthetic Thermally Bonded White Media
- 11.0 Pleats Per Foot
- Expanded Metal Pleat Supports
- Moisture Resistant Beverage Board Frame
- Double Wall Frame
- (2) Rows of Fingers on Air Entering Side

NOTES

- MERV 8 Per ASHRAE 52.2-2012
MERV-A 8-A Per ASHRAE 52.2-2012 Appendix J
- Final Resistance: 1.0" W.G.
- Rated Velocity: 500 FPM
- Classified Per UL Standard 900 for Flammability
- Maximum Operating Temperature: 225 deg. F



100 River Ridge Circle
Jeffersonville, IN 47130
P: 866-247-4827
F: 866-801-1809
www.clcair.com/airguard

CONTACT FACTORY TO
VERIFY REVISION LEVEL

**TOLERANCES
UNLESS OTHERWISE SPECIFIED**

FRACTIONAL -
DECIMAL -
ANGLES -

ALL DIMENSIONS IN INCHES

DRAWING NAME

DP PLEAT (4" DEPTH)

APPROVED BY

K. Quinn

SPECIFICATION NO.

MKT-B-00553

PAGE 1 OF 1

SCALE

NONE

DWG. SIZE

A

REVISION

G

REVISION DATE

12-06-2016

CONFIDENTIAL - DO NOT COPY. THIS MATERIAL IS TRADE SECRET AND PROPRIETARY BEING EXCLUSIVELY OWNED BY CLCAIR. THE EXPRESSION OF THE INFORMATION CONTAINED HEREIN IS PROTECTED UNDER FEDERAL COPYRIGHT LAWS AND ALL COPYING IS PROHIBITED AND MAY BE SUBJECT TO CRIMINAL PENALTIES.